

ION7550 RTU

Functions and characteristics



PowerLogic ION 7550 RTU.

The PowerLogic ION7550 RTU (remote terminal unit) is an intelligent web-enabled device ideal for combined utilities metering of water, air, gas, electricity and steam (WAGES). When combined with PowerLogic software, the ION7550 RTU offers a seamless, end-to-end WAGES metering solution. Featuring a large, high-visibility display and overall versatility of the PowerLogic system, the ION7550 RTU provides extensive analogue and digital I/O choices and is a cost-effective dedicated WAGES solution when compared to a traditional meter. The device automatically collects, scales and logs readings from a large number of connected meters or transducers and delivers information to one or more head-end systems through a unique combination of integrated Ethernet, modem or serial gateways. As part of a complete enterprise energy management solution, the ION7550 RTU can be integrated with PowerLogic ION Enterprise software, or other SCADA, information and automation systems.

Applications

- WAGES metering.
- Data concentration through multi-port, multi-protocol communications.
- Equipment status monitoring and control.
- Programmable setpoints for out-of-limit triggers or alarm conditions.
- Integrated utility metering with advanced programmable math functions.

Main characteristics

Increase efficiency

Reduce waste and optimise equipment operation to increase efficiency.

Easy to operate

Screen-based menu system to configure meter settings. Bright LCD display with adjustable contrast.

Integrate with software

Easily integrated with PowerLogic or other energy management enterprises, including SCADA systems.

Transducer and equipment condition monitoring

Versatile communications, extensive I/O points, clock synchronization, event logging and sequence of events recording capabilities for transducer and equipment condition and status monitoring at utility substations.

Set automatic alarms

Alarm setpoint learning feature for optimum threshold settings.

Up to 10 Mbytes of memory

For archiving of data and waveforms.

Notify alarms via email

High-priority alarms sent directly to the user's PC. Instant notification of power quality events by email.

Modbus Master functionality

Aggregate and store data from downstream Modbus devices using serial or Ethernet connections.

Part numbers

ION7550 RTU	
ION7550	M7550

See page 133 for order code explanations.

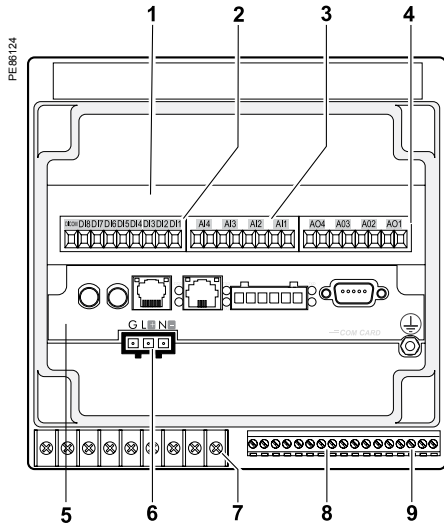

PowerLogic® ION7550 RTU.

- 1 I/O expansion card.
- 2 Digital inputs.
- 3 Analogue inputs.
- 4 Analogue outputs.
- 5 Communications card.
- 6 Power supply.
- 7 Form C digital outputs.
- 8 Digital inputs.
- 9 Form A digital outputs.

Selection guide	ION7550 RTU
Data recording	
Min/max of instantaneous values	β
Data logs	β
Event logs	β
Trending	β
SER (Sequence of event recording)	β
Time stamping	β
GPS synchronisation (1 ms)	β
Memory (in Mbytes)	10
Display and I/O	
Front panel display	β
Pulse output	1
Digital or analogue inputs(max)	24
Digital or analogue outputs (max, including pulse output)	30
Communication	
RS 485 port	1
RS 485 / RS 232 port	1
Optical port	1
Modbus TCP Master / Slave (Ethernet port)	β / β
Modbus RTU Master / Slave (Serial port)	β / β
Ethernet port (Modbus/TCP/IP protocol)	1
Ethernet gateway (EtherGate)	1
Alarms (optional automatic alarm setting)	β
Alarm notification via email (Meterm@il)	β
HTML web page server (WebMeter)	β
Internal modem	1
Modem gateway (ModemGate)	β
DNP 3.0 through serial, modem, and I/R ports	β

ION7550 RTU

Functions and characteristics (cont.)

PE8817



PowerLogic ION7550 RTU.

Electrical characteristics

Data update rate		1/2 cycle or 1 second
Power supply	AC	85-240 V AC $\pm 10\%$ (47-63 Hz)
	DC	110-300 V DC $\pm 10\%$
	DC low voltage (optional)	20-60 V DC $\pm 10\%$
	Ride-through time	100 ms (6 cycles at 60 Hz) min. at 120 V DC
	Burden	Standard: typical 15 VA, max 35 VA Low voltage DC: typical 12 VA, max 18 VA
Input/outputs ⁽¹⁾	Standard	8 digital inputs (120 V DC) 3 relay outputs (250 V AC / 30 V DC) 4 digital outputs (solid state)
	Optional	8 additional digital inputs 4 analogue outputs, and/or 4 analogue inputs

Mechanical characteristics

Weight		1.9 kg
IP degree of protection (IEC 60529)		IP52
Dimensions	Standard model	192 x 192 x 159 mm
	TRAN model	235.5 x 216.3 x 133.1 mm

Environmental conditions

Operating temperature	Standard power supply	-20 to +70°C
	Low voltage DC supply	-20 to +50°C
	Display operating range	-20 to +70°C
Storage temperature	Display, TRAN	-40 to +85°C
Humidity rating		5 to 95% non-condensing
Installation category		III (2000m above sea level)
Dielectric withstand		As per EN 61010-1, IEC 62051-22A ⁽²⁾

Electromagnetic compatibility

Electrostatic discharge		IEC 61000-4-2
Immunity to radiated fields		IEC 61000-4-3
Immunity to fast transients		IEC 61000-4-4
Immunity to surges		IEC 61000-4-5
Conducted and radiated emissions		CISPR 22

Safety

Europe		IEC 61010-1
--------	--	-------------

⁽¹⁾ Consult the ION7550 / ION7650 installation guide for complete specifications.

⁽²⁾ IEC 62051-22B with serial ports only.

ION7550 RTU

Functions and characteristics (cont.)

Communication	
RS 232/485 port ⁽¹⁾	Up to 115,200 bauds (57,600 bauds for RS 485), ION, DNP 3.0, Modbus, GPS, EtherGate, ModemGate, Modbus Master
RS 485 port ⁽¹⁾	Up to 115,200 bauds, ION, DNP 3.0, Modbus, GPS, EtherGate, ModemGate, Modbus Master
Infrared port ⁽¹⁾	ANSI type 2, up to 19,200 bauds, ION, Modbus, DNP 3.0
Ethernet port	10BaseT, 100BaseTX. RJ45 connector, 10/100 m link
Fibre-optic Ethernet link	100Base FX, SC duplex connector, 1300 nm, FO multimode with gradient index 62.5/125 µm or 50/125 µm, 2000 m link
Protocol	ION, Modbus, Modbus Master, TCP/IP, DNP 3.0, Telnet
EtherGate	Communicates directly with up to 62 slave devices via available serial ports
ModemGate	Communicates directly with up to 31 slave devices
WebMeter	5 customisable pages, new page creation capabilities, HTML/XML compatible
Firmware characteristics	
High-speed data recording	Down to 5ms interval burst recording, stores detailed characteristics of disturbances or outages. Trigger recording by a user-defined setpoint, or from external equipment.
Load profiling	Channel assignments (800 channels via 50 data recorders) are configurable for any measurable parameter. Trigger recorders based on time interval, calendar schedule, alarm/event condition, or manually.
Trend curves	Access historical data at the front panel. Display, trend and continuously update historical data with date and timestamps for up to four parameters simultaneously.
Alarms	Threshold alarms: adjustable pickup and dropout setpoints and time delays, numerous activation levels possible for a given type of alarm user-defined priority levels boolean combination of alarms is possible using the operators NAND, OR, NOR and XOR
Advanced security	Up to 16 users with unique access rights. Perform resets, time syncs, or meter configurations based on user privileges
Memory	5 to 10 Mbytes (specified at time of order)
Firmware update	Update via the communication ports
Display characteristics	
Integrated display	Back lit LCD, configurable screens
Languages	English

⁽¹⁾ All the communication ports may be used simultaneously.

ION7550 RTU

Functions and characteristics (cont.)

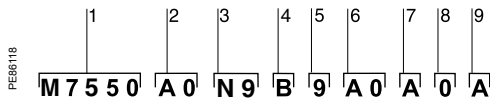

Sample ION7550 RTU part number.

Part numbers

Item	Code	Description
1 Model	7550	ION7550 device
2 Form Factor	A0	Integrated display with front optical port, 5 MB logging memory, and 512 samples/cycle resolution.
	B0	Integrated display with front optical port, 10 MB logging memory, and 512 samples/cycle resolution.
	T0	Transducer (no display) version, with 5 MB logging memory.
	U0	Transducer (no display) version, with 10 MB logging memory.
3 RTU option	N9	RTU option
4 Power Supply	B	Standard power supply (85-240 VAC, ±10%/47-63 Hz / 110-330 VDC, ±10%)
	C	Low voltage DC power supply (20-60 VDC)
5 Internal use	9	This field for internal use only
6 Communications	A0	Standard communications (1 RS-232/RS-485 port, 1 RS-485 port). Integrated display models also include 1 ANSI Type 2 optical communications port.
	C1	Standard communications plus 10BASE-T/100BASE-TX Ethernet (RJ-45), 56k universal internal modem (RJ-11). Ethernet, modem gateway functions each use a serial port.
	D7	Standard comms plus 10BASE-T/100BASE-TX Ethernet (RJ-45) and 100BASE-FX Ethernet Fiber, 56k universal internal modem (RJ-11). Ethernet and modem gateway functions each use a serial communications port.
	E0	Standard communications plus 10BASE-T/100BASE-TX Ethernet (RJ-45). Ethernet gateway function uses serial port.
	F1	Standard communications plus 10BASE-T/100BASE-TX Ethernet (RJ-45) and 100BASE-FX (SC fiber optic connection). Ethernet gateway uses a serial port.
	M1	Standard communications plus 56k universal internal modem (RJ-11). Modem gateway uses serial communications port.
7 I/O	A	Standard I/O (8 digital inputs, 3 Form C relays, 4 Form A solid-state outputs)
	D	Standard I/O plus Expansion I/O card (8 additional digital inputs & four 0 to 1 mA analogue inputs)
	E	Standard I/O plus Expansion I/O card (8 additional digital inputs & four 0 to 20 mA analogue inputs)
	H	Standard I/O plus Expansion I/O card (8 additional digital inputs & four -1 to 1 mA analogue outputs)
	K	Standard I/O plus Expansion I/O card (8 additional digital inputs & four 0 to 20 mA analogue outputs)
	N	Standard I/O plus Expansion I/O card (8 additional digital inputs & four 0 to 20 mA analogue inputs and four 0 to 20 mA outputs)
	P	Standard I/O plus Expansion I/O card (8 additional digital inputs & four 0 to 1 analogue inputs and four -1 to 1 mA analogue
8 Security	0	Password protected, no hardware lock
9 Special Order	A	None
	C	Tropicalisation treatment applied

ION7550 RTU

Functions and characteristics (cont.)

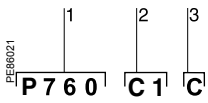

Example order code. Use this group of codes when ordering the PowerLogic ION7550 RTU communication or I/O card.

- 1 Communications or I/O card.
- 2 Type.
- 3 Special order.

Communications Card		
Item	Code	Description
1	Comm card	P765C ION7550 RTU communication card for field retrofit installations
2	Type	A0 Standard communications (1 RS-232/RS-485 port, 1 RS-485 port). Front optical port support for meters with integrated display.
	C1 Standard communications plus 10BASE-T/100BASE-TX Ethernet (RJ-45), 56k universal internal modem (RJ-11; the modem port is shared with the front optical port). Ethernet and modem gateway functions each use a serial communications port.	
	D7 Standard communications plus 10BASE-T/100BASE-TX Ethernet, 100BASE-FX Ethernet Fiber, 56k universal internal modem (RJ-11; the modem port is shared with the front optical port). Ethernet and modem gateway functions each use a serial communications port.	
	E0 Standard communications plus 10BASE-T/100BASE-TX Ethernet. Ethernet gateway function uses a serial communications port.	
	F1 Standard communications plus 10BASE-T/100BASE-TX Ethernet, 100BASE-FX Ethernet Fiber (SC fiber optic connection). Ethernet gateway function uses a serial communications port.	
	M1 Standard communications plus 56k universal internal modem (RJ-11; the modem port is shared with the front optical port). Modem gateway function uses a serial communications port.	
	3	Special order
		C Tropicalization treatment applied

ION7550 RTU

Functions and characteristics (cont.)

Part numbers (cont'd)

Input/Output expansion card

Item	Code	Description
I/O card	P760A	Expansion I/O for field retrofit installations.
Type	D	Expansion I/O card with eight digital inputs, four 0 to 1 mA analogue inputs
	E	Expansion I/O card with eight digital inputs, four 0 to 20 mA analogue inputs
	H	Expansion I/O card with eight digital inputs, four -1 to 1 mA analogue outputs
	K	Expansion I/O card with eight digital inputs, four 0 to 20 mA analogue outputs
	N	Expansion I/O card with eight digital inputs, four 0 to 20 mA analogue inputs & four 0 to 20 mA outputs
	P	Expansion I/O card with eight digital inputs, four 0 to 1 analogue inputs and four -1 to 1 mA analogue outputs
Special Order	A	None
	C	Tropicalization treatment applied

OpenDAC rack, controllers, power supply

70LRCK16-48	OpenDAC rack. Holds up to 8 OpenLine modules to provide up to 16 I/O points. Requires communications controller
72-MOD-4000	OpenDAC OpenDAC RS-485 serial module. Communications controller for use in a Modbus RTU network. Supports up to 2 70LRCK16-48 OpenDAC racks
72-ETH-T000	OpenDAC Ethernet network module for use on an Modbus/TCP Ethernet network. Supports up to 2 OpenDAC racks
PS-240-15W	85-264VAC/110-370VDC 15 Watt power supply. Required for applying power to the racks and controllers

OpenLine digital I/O modules

70L-IAC	digital input, 120VAC
70L-IACA	digital input, 220VAC
70L-IDC	digital input, 3-32VDC
70L-IDCB	digital input, fast switching
70L-IDCNP	digital input, 15-32VAC/10-32VDC
70L-IDC5S	dry contact closure-sensing DC input
70L-ISW	input test module
70L-OAC	digital output, 120VAC
70L-OACL	digital output, 120VAC inductive loads
70L-OACA	digital output, 220VAC
70L-OACAL	digital output, 220VAC inductive loads
70L-ODC	digital output, 3-60VDC fast
70L-ODCA	digital output, 4-200 VDC
70L-ODCB	digital output, fast switching
70L-ODC5R	digital output, dry contact

OpenLine analogue I/O modules

73L-II020	analogue input, current, 0-20mA
73L-II420	analogue input, current, 4-20mA
73L-ITCJ	analogue input, temperature, J-type TC
73L-ITCK	analogue input, temperature, K-type TC
73L-ITCT	analogue input, temperature, T-type TC
73L-ITR100	analogue input, temperature, RTD
73L-ITR3100	analogue input, temperature, 3wire RTD
73L-ITR4100	analogue input, temperature, 4wire RTD
73L-IV1	analogue input, voltage, 0-1VDC
73L-IV10	analogue input, voltage, 0-10VDC
73L-IV10B	analogue input, voltage, -10 to 10VDC
73L-IV100M	analogue input, voltage, 0-100VDC
73L-IV5	analogue input, voltage, 0-5VDC
73L-IV5B	analogue input, voltage, -5 to 5VDC
73L-IV50M	analogue input, voltage, 0-50mV
73L-OI020	analogue output, current, 0-20mA
73L-OI420	analogue output, current, 4-20mA
73L-OV10	analogue output, voltage, 0-10VDC
73L-OV10B	analogue output, voltage, -10 to 10VDC
73L-OV5	analogue output, voltage, 0-5VDC
73L-OV5B	analogue output, voltage, -5 to 5VDC

ION7550 RTU

Dimensions and connection

ION7550 RTU dimensions

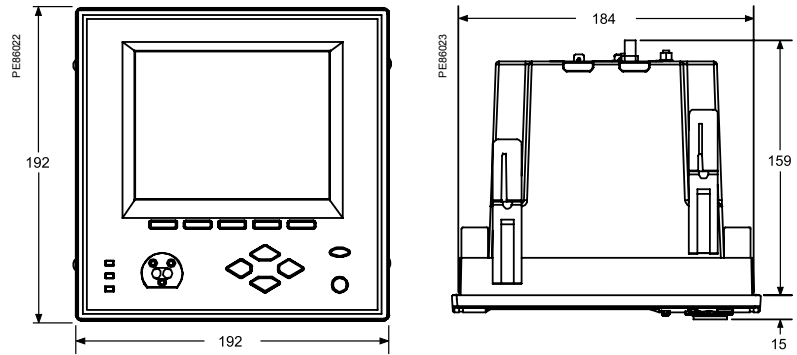

Front-panel mounting

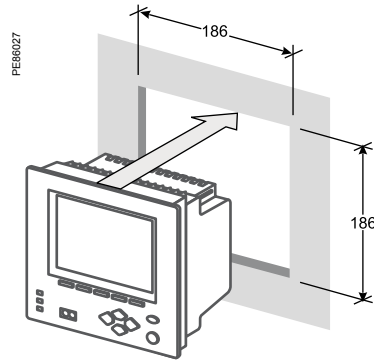

Power supply

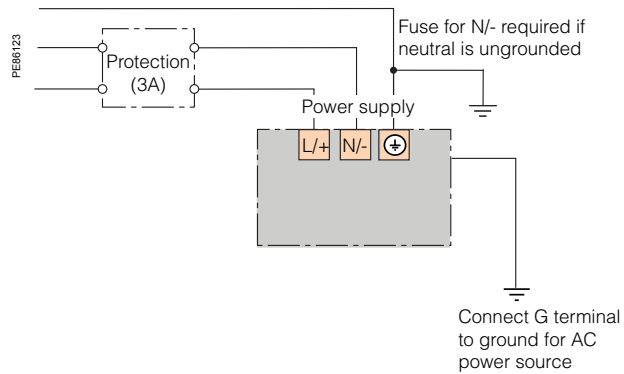

Note: the current and voltage terminal strip (I52, I51, I42, I41, I32, I31, I22, I21, I12, I11, V4, V3, V2, V1, Vref) is not present on the RTU.